

400 Series Electrical Latch Retraction Touch Bar



SED403-ELR-SC

The 400 series Electrical Latch Retraction Touch Bar links panic hardware with access control and is ideal for controlling entry into a building whilst maintaining an easy escape.

Available with a single latch, two point vertical Pullman catches or three point horizontal latches in a standard Silver or Satin Chrome finish making the range ideal for almost any final exit door.

To compliment the range a complete Access Control package is available containing the APX16 IP65 rated Key Pad, a 1 amp PSU and concealed door loop.

The APX16 Keypad for access from the outside of the door is IP65 rated which means it can be installed in the most extreme of environments as the wiring has total protection against the ingress of dust and the unit is protected against long periods of immersion under pressure.

The strong Zinc Alloy Electroplated case also offers a reasonable amount of protection against vandalism.

Features & Benefits – Touch Bar

- Tested and certified to EN1125 (Classification Code 3-7-7-B-1-4-2-2-B-A)
- Fire tested to EN1634-1
- Available with a micro-switch contained in the operating mechanism
- Available with hold-back facility
- Operates on 12 – 30v dc 12 – 20v ac with 1 amp PSU
- Standard size touch bar is 840mm which is suitable for doors up to 860mm wide. Additional wide units 1170mm and 1300mm are available on request
- Strikers are available for PVC-U, Aluminium and Steel Doors
- Manual Outside Access Device fitted with a Euro Single Cylinder can be used as an alternative to the Electrical Keypad



SED400-KIT

400 Series Electrical Latch Retraction Touch Bar

Technical Drawing

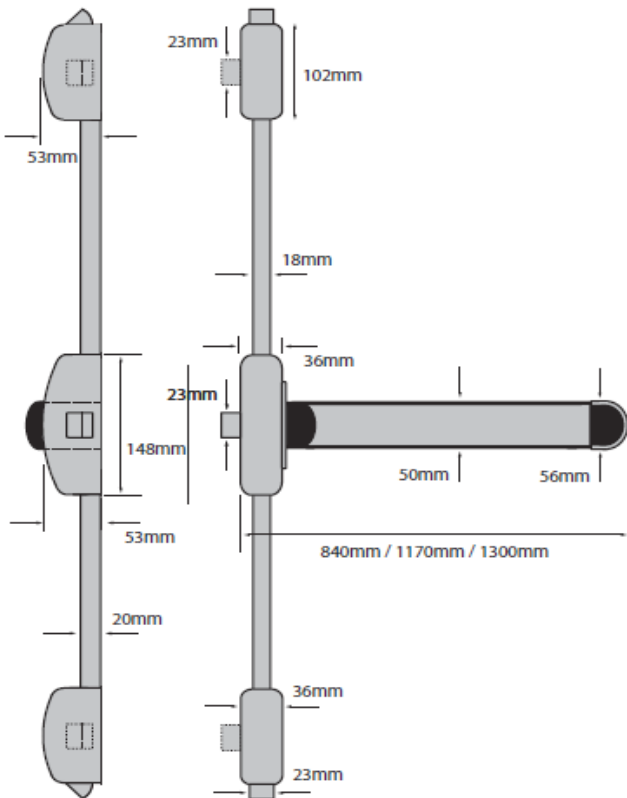

Features & Benefits – Keypad

- Two relays operation, lock and alarm
- Pulse mode, Toggle mode
- Pin length: 4 – 8 digits
- Block enrolment, can enrol 1500 consecutive cards within 10 seconds
- Waterproof, conforms to IP65
- Strong Zinc Alloy Electroplated anti-vandal case
- The APX16 Keypad has keys which are backlit for easy visibility in low lit areas such as porches under canopies and in areas with little or no street lighting and being just 58mm wide enables it to be fitted to most architraves

Features & Benefits – Power Supply Unit

- High efficiency electronics for reduced running costs and lower operating temperatures
- Installer safe design with all high voltage electronically fully shrouded
- Full electronic short circuit and overload protection on load output under mains operation
- Mains transient protection
- Lid open and REAR anti-vandal tamper detection
- Greens Mains present LED
- Red fault LED

| Product Code | Description |
|---------------|---|
| SED401-ELR-SE | Single Latch ELR Touch Bar Silver |
| SED402-ELR-SE | Two Point ELR Touch Bar Silver |
| SED403-ELR-SE | Three Point ELR Touch Bar Silver |
| SED401-ELR-SC | Single Latch ELR Touch Bar Satin Chrome |
| SED402-ELR-SC | Two Point ELR Touch Bar Satin Chrome |
| SED403-ELR-SC | Three Point ELR Touch Bar Satin Chrome |
| SED400-KIT | Access Control Kit |